

1 DESCRIPTION

The Model CBL-C2 cryocable simplifies interfacing between STAR Cryoelectronics' standard SQUID sensor packages and single-channel Programmable Feedback Loops Models PFL-100 and PFL-102.

Standard cryocables are assembled using a stainless steel braided shield; cryocables with optional solid stainless steel shields offering 100% shielding against electromagnetic interference (EMI) are available by special order. Standard wiring includes multiple twisted pairs of 0.005 (125 μ m) OD phosphor-bronze and copper wire with heavy polyimide insulation. The warm-end connector housing is vacuum sealed and may be installed through a 1/2-inch opening. Two 4-40 bolt holes are available to securely mount the warm-end connector housing to a cryostat flange.

The standard cable length is 1 meter; custom lengths and optional heat sinks for vacuum installations are available by special order.

FEATURES

- Stainless steel braided shield or optional solid stainless steel shield to minimize thermal loss.
- Vacuum sealed bulkhead connector housing may be bolted directly to cryostat flange.
- Mates with all STAR Cryoelectronics SQUID sensors and single-channel Programmable Feedback Loop electronics.

2 ORDER INFORMATION

The standard model numbers for CBL-C2 cryocables are summarized in the table below. For custom cables including optional heat sinks, please contact STAR Cryoelectronics.

Model	Description
CBL-C2-10-L	Standard 10-pin, overall length L (in meters)
CBL-C2-10W-L	Standard 10-pin, warm connector only, overall length L (in meters); cold end terminates with 10 cm of wire pigtailed
CBL-C2-10C-L	Standard 10-pin, cold connector only, overall length L (in meters); warm end terminates with 10 cm of wire pigtailed
CBL-C2-14-L	Standard 14-pin, overall length L (in meters)
CBL-C2-14W-L	Standard 14-pin, warm connector only, overall length L (in meters); cold end terminates with 10 cm of wire pigtailed
CBL-C2-14C-L	Standard 14-pin, cold connector only, overall length L (in meters); warm end terminates with 10 cm of wire pigtailed

3 SPECIFICATIONS

Item	Description	CBL-C2-10	CBL-C2-14
PFL		PFL-100	PFL-102
Warm Connector		LEMO EHG.1B.310.CLL	LEMO EHG.1B.314.CLL
Cold Connector		LEMO EGG.1B.310.ZLL	LEMO EGG.1B.314.ZLL
Braided Shield	.002 OD stainless steel, six wires per bundle, wrapped on PTFE tube core, .038 ID, .062 OD; overall OD .094		
Solid Shield	Type 304 stainless steel, seamless, .062 OD, .006 wall		
Ph-Br Leads	Cu (94.8%), Sn (5%), Ph (.2%); .005 OD, twisted pair (7-10 TPI), polyimide insulation, red/green,	3 pair	4 pair
Resistance	9.07 Ohms/meter		
Thermal Conductivity	0.699 W/cm-°C		
Cu Leads	Cu, 99.99%; .005 OD, twisted pair (7-10 TPI), polyimide insulation, clear/green	2 pair	2 pair
Resistance	1.35 Ohms/meter		
Thermal Conductivity	3.84 W/cm-°C		

3.1 Pin Assignments, CBL-C2-10 (10-Pin Cryocables)

Sensor	Cold End	Wire Type	Warm End	PFL-100	Resistance ¹ [Ω]
+H	1	Copper	1	+H	2
+V	2	Copper	2	+V	2
-V	3	Copper	3	-V	2
-H	4	Copper	4	-H	2
-FB	5	Ph-Bronze	5	-FB	10
+FB	6	Ph-Bronze	6	+FB	10
+M	7	Ph-Bronze	7	+M	10
+I	8	Ph-Bronze	8	+I	10
-I	9	Ph-Bronze	9	-I	10
-M	10	Ph-Bronze	10	-M	10

¹Resistances are typical values for standard 1-meter cable length.

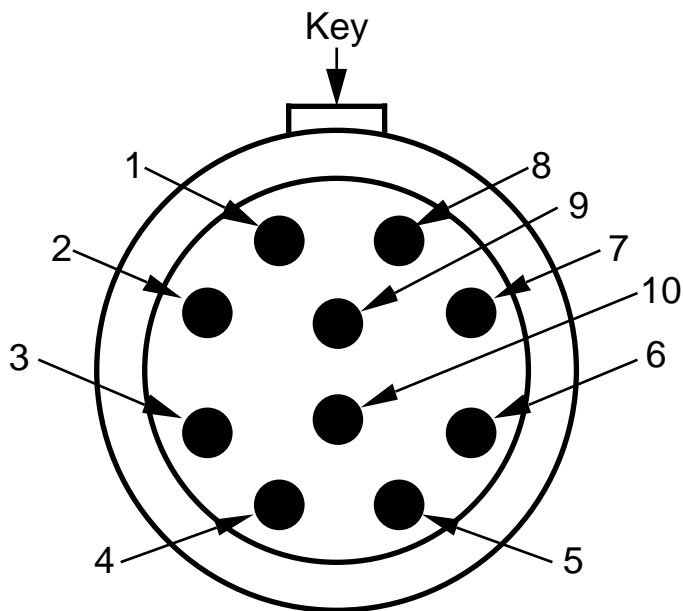

Pin numbering scheme for the cryocable connectors (LEMO receptacle), as seen when looking at the connector. The Key refers to the keyed slot on the warm end receptacle and the tab on the cold end connector.

3.2 Pin Assignments, 14-Pin Cryocables

Sensor	Cold End	Wire Type	Warm End	PFL-102	Resistance ¹ [Ω]
+V	1	Copper	1	+V	2
-V	2	Copper	2	-V	2
N/C	3		3	N/C	
-I1	4	Ph-Bronze	4	-I1	10
+I1	5	Ph-Bronze	5	+I1	10
+H	6	Copper	6	+H	2
-H	7	Copper	7	-H	2
N/C	3		8	N/C	
+FB1	9	Ph-Bronze	9	+FB1	10
-FB1	10	Ph-Bronze	10	-FB1	10
-I2	11	Ph-Bronze	11	-I2	10
+I2	12	Ph-Bronze	12	-FB2	10
+FB2	13	Ph-Bronze	13	+FB2	10
-FB2	14	Ph-Bronze	14	+I2	10

¹Resistances are typical values for standard 1-meter cable length.

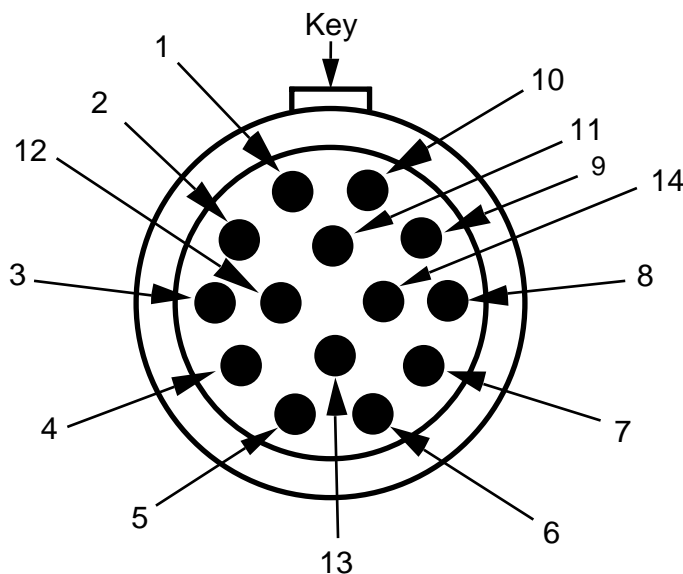

Pin numbering scheme for the cryocable connectors (LEMO receptacle), as seen when looking at the connector. The Key refers to the keyed slot on the warm end receptacle and the tab on the cold end connector.

4 INSTALLATION

1. Locate a suitable mounting site for the warm end connector housing of the cryocable. Be sure to allow sufficient space for the Programmable Feedback Loop that will be plugged into the cryocable.
2. The opening for the warm connector housing should have an ID of 0.518, with a 0.570 ID, 0.050 deep counterbore to accommodate a standard 2-014 o-ring (included with the cryocable). In addition, two tapped 4-40 holes spaced 0.875 are needed to securely mount the warm connector housing to the flange. Two 4-40x7/8 stainless steel cap screws are included with the cryocable for this purpose. See mechanical specifications in Section 5.
3. Install the o-ring over the stem on the warm connector housing, then pass the cold end of the cryocable through the ½-inch opening in the mounting flange. If the cryocable has a solid shield, bend and form the cable as necessary to reach the SQUID sensor. Gradual bends may be formed by hand, while small bends with a diameter down to 3/8 inch (9.5 mm) should be formed using a piece of round stock. Avoid using very tight bends with a diameter below 5/16 inch (8 mm). Attach the cryocable to the SQUID.
4. If it is ever necessary to remove the cold connector shell on the cryocable, slide the shell back and remove split ring around the connector body. Use a small screwdriver blade to separate the ring, then use two pair of pliers to spread the ring apart so it may be removed from the cable. Now slide the connector shell off the cable. Set the split ring and connector shell aside in a safe place.
5. If the cold connector shell has been removed from the cryocable, it must be reinstalled before connecting the cable to the SQUID. Slide the connector shell back onto the cable and install the split ring. Use a pair of pliers to close the split ring until it is snug around the connector body. There should be a small gap in the ring after compression - *do not over compress, as this may damaged the connector assembly*. Slide the connector shell over the ring. If the connector shell cannot be slid to the end of the cable, gradually compress and adjust the split ring as necessary.

5 MECHANICAL SPECIFICATIONS

5.1 CBL-C2-10

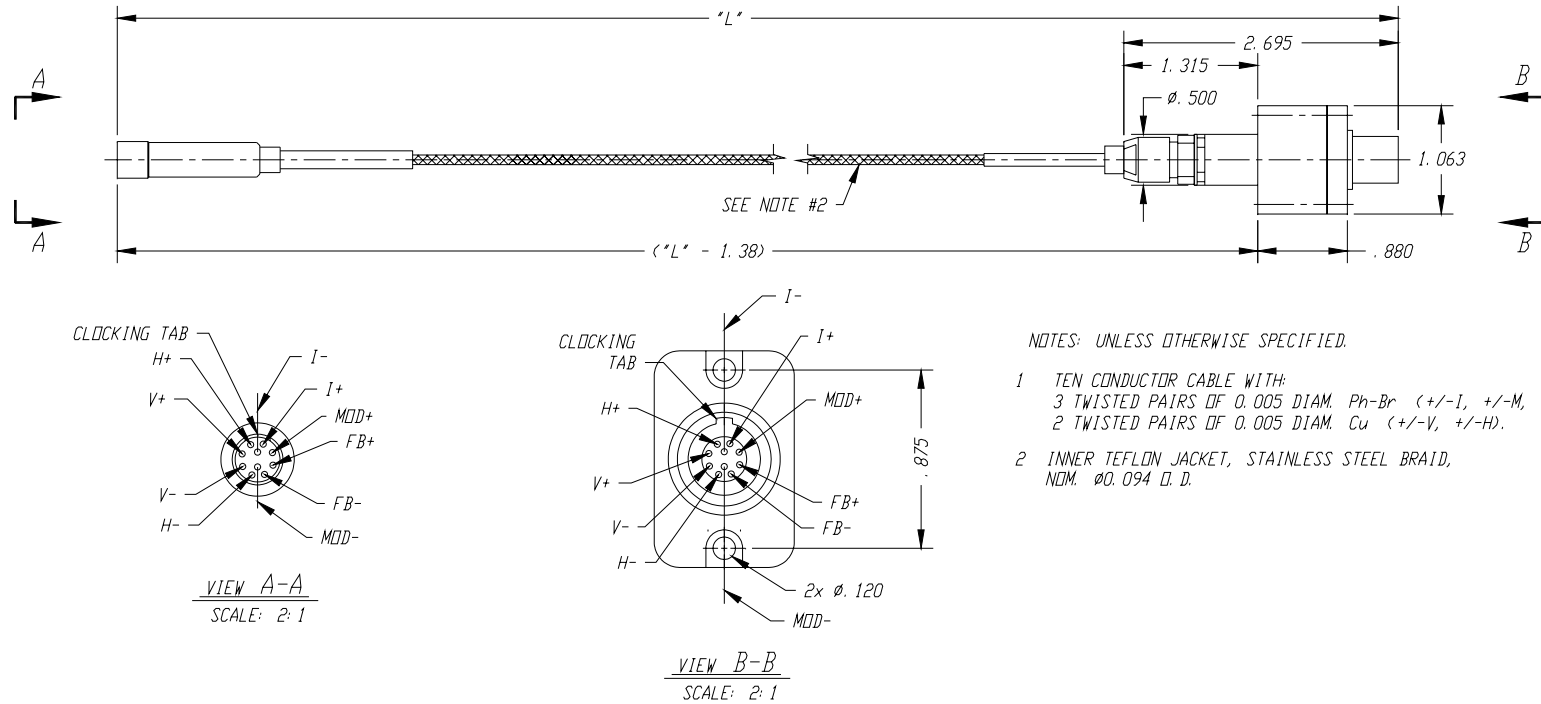

Mechanical specifications, Model CBL-C2-10 cryocable with 10-pin LEMO connectors. The standard length L is 1 meter.

5.2 CBL-C2-14

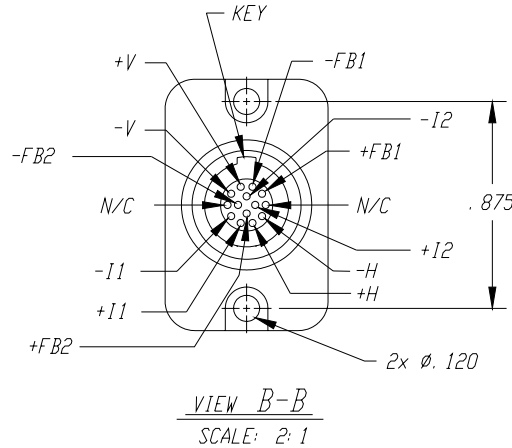
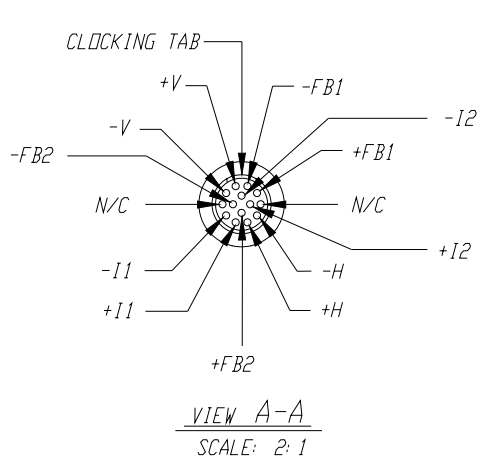
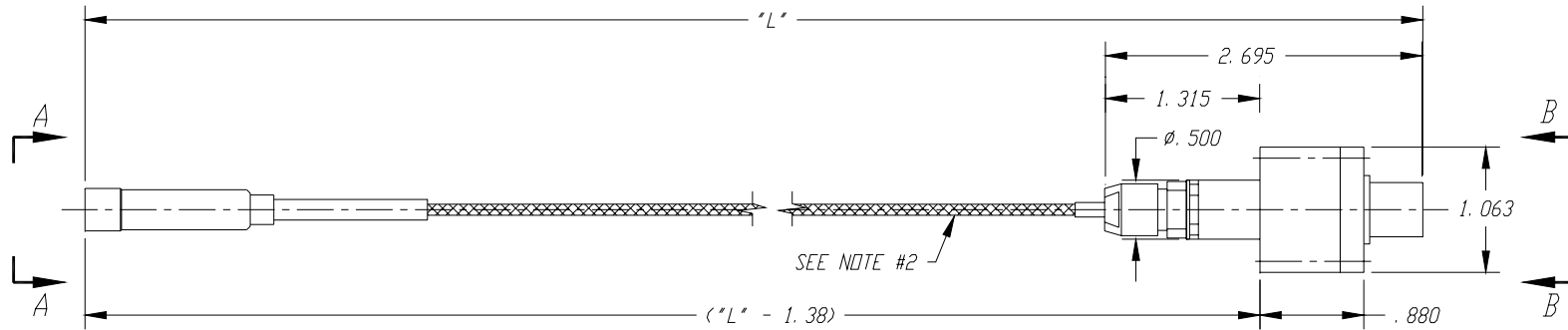

NOTES: UNLESS OTHERWISE SPECIFIED.

1. TWELVE CONDUCTOR CABLE WITH:
4 TWISTED PAIRS OF 0.005 DIAM. Ph-Br
(+/-I1, +/-I2, +/-FB1, +/-FB2)
2. TWISTED PAIRS OF 0.005 DIAM. Cu (+/-V, +/-H).

Mechanical specifications, Model CBL-C2-14 cryocable with 14-pin LEMO connectors. The standard length L is 1 meter.